



For Use in CCO Written Examinations

# TELESCOPIC BOOM CRANE—SWING CAB (TLL)

*These charts have been adapted from the original manufacturer's charts for use in CCO written examinations.*

***This supplement is not to be used for any other purpose.***

®

Copyright 1996–2023 National Commission for the Certification of Crane Operators (CCO).  
All rights reserved. This document may not be reproduced in whole or in part without express  
written permission of the manufacturer and the consent of CCO.

## **HOLD HARMLESS/RELEASE AGREEMENT**

The user of this publication for and in consideration of the assistance, cooperation, and information provided by the National Commission for the Certification of Crane Operators (CCO) in this publication, *Mobile Crane Load Chart Manual*, the receipt of which is acknowledged, does hereby and for all future time release and hold harmless from any liability, and forever discharge for itself, its administrators and assigns the said CCO from all and any manner of action or demands whatsoever in law, in admiralty, or in equity, which against CCO anyone ever had, now have, or which shall later be claimed. This Agreement relates specifically to any cause of action arising out of the publication, information provided, subsequent conduct, and any use of the information provided in this publication and related uses or demonstrations of skills, methods, and techniques cited in the publication. This mutually beneficial release and hold-harmless agreement may not be changed orally and exists in perpetuity. This publication is issued solely as a public service to improve the lifting industry and promote public safety.

## **NO WARRANTY**

Information and materials provided in this *Mobile Crane Load Chart Manual* are provided “as is” without warranty of any kind, either express or implied, including without limitation warranties of merchantability, fitness for a particular purpose, and non-infringement. CCO specifically does not make any warranties or representations as to the accuracy or completeness of any such information and materials. Under no circumstances shall CCO be liable for any loss, damage, liability, or expense incurred or suffered which is claimed to have resulted from use of this publication, including without limitation, any fault, error, omission, interruption, or delay with respect thereto. Use of this publication is at user’s sole risk. Under no circumstances, including, but not limited to, negligence, shall CCO be liable for any direct, indirect, incidental, special, or consequential damages, even if CCO has been advised of the possibility of such damages.

Copyright 1996–2023 by the National Commission for the Certification of Crane Operators. All rights reserved. No part of this book may be reproduced or transmitted in any form or by any means, electronic or mechanical, including photocopying, recording, or by any information storage and retrieval system, without prior written permission from the publisher. For information, contact the publisher, the National Commission for the Certification of Crane Operators, at [info@nccco.org](mailto:info@nccco.org).



# WARNING

READ AND UNDERSTAND THE OPERATOR'S AND SAFETY MANUAL AND THE FOLLOWING INSTRUCTIONS AND CHART VALUES BEFORE OPERATING THE CRANE. OPERATION WHICH DOES NOT FOLLOW THESE INSTRUCTIONS MAY RESULT IN AN ACCIDENT.

## OPERATING INSTRUCTIONS

### GENERAL:

1. Rated lifting capacities in pounds as shown on lift charts pertain to this crane as originally manufactured and normally equipped. Modifications to the crane or use of optional equipment other than that specified can result in a reduction of capacity.
2. Construction equipment can be dangerous if improperly operated or maintained. Operation and maintenance of this crane must be in compliance with the information in the Operator's, Parts and Safety Manuals supplied with this crane. If these manuals are missing, order replacements through the distributor.
3. The operator and other personnel associated with this crane shall read and fully understand the latest applicable American National Standards Institute (ANSI) safety standards for cranes.
4. The maximum allowable lifting capacities are based on crane standing level on firm supporting surface.

### SET UP:

1. The crane shall be leveled on a firm supporting surface. Depending on the nature of the supporting surface, it may be necessary to have structural supports under the outrigger pontoons or tires to spread the load to a larger bearing surface.
2. When making lifts on outriggers, all tires must be free of supporting surface. All outrigger beams must be extended to the same length; fully retracted, intermediate, or fully extended.
3. When making lifts on tires, they must be inflated to the recommended pressure. (See Operation note 19 and Tire Inflation.)
4. When operating on tires, do not exceed 76-degree maximum boom angle. Loss of backward stability will occur causing a tipping condition.
5. For required parts of line, see Wire Rope Strength and Winch Performance.

### OPERATION:

1. Rated lifting capacities at rated radius shall not be exceeded. Do not tip the crane to determine allowable loads. For concrete bucket operation, weight of bucket and load shall not exceed 80%

- of rated lifting capacities. For clamshell bucket operation, weight of bucket and bucket contents is restricted to a maximum weight of 7000 pounds or 80% of rated lifting capacity, whichever is less. For magnet operation, weight of magnet and load is restricted to a maximum weight of 7000 pounds or 80% of rated lifting capacity, whichever is less. For clamshell and magnet operation, maximum boom length is restricted to 55 feet and the boom angle is restricted to a minimum of 35 degrees. Lifts with either fly erected or boom in "Mode A" are prohibited for both clam and magnet operation.
2. The crane capacities shown on fully extended, or intermediate extended outriggers do not exceed 85% of the tipping loads. The crane capacities shown on fully retracted outriggers or tires do not exceed 75% of the tipping loads as determined by SAE crane stability test code J-765A.
  3. The crane capacities in the shaded areas above the bold lines, are based on structural strength or hydraulic limitations. The crane capacities below the bold lines are based on stability ratings. Some capacities are limited by a maximum obtainable 78° boom angle.
  4. Rated lifting capacities include the weight of hook block, slings, bucket, magnet and auxiliary lifting devices. Their weights must be subtracted from the listed rated capacity to obtain the net load which can be lifted. Also, see Capacity Deductions For Auxiliary Load Handling Equipment.
  5. Rated lifting capacities are based on freely suspended loads. No attempt shall be made to move a load horizontally on the ground in any direction.
  6. Rated lifting capacities are for lift crane service only.
  7. Do not operate at any radii or boom lengths (minimum or maximum) where capacities are not listed. At these positions, the crane can overturn without any load on the hook or cause boom failure.
  8. The maximum loads which can be telescoped are not definable because of variation in loadings and crane maintenance, but it is permissible to attempt retraction and extension within the limits of the applicable load rating chart.
  9. For the main boom capacities when either boom length or radius or both are between values listed, proceed as follows:

- a. For boom lengths not listed, use rating for next longer boom length or next shorter boom length, whichever smaller.
  - b. For load radii not listed, use rating for next larger radius.
10. The user shall operate at reduced ratings to allow for adverse job conditions, such as: soft or uneven ground, out of level conditions, wide, side loads, pendulum action, jerking or sudden stopping of loads, hazardous conditions, experience of personnel, travelling with loads, electrical wires, etc. Side load on boom or fly is extremely dangerous.
  11. When making lifts with auxiliary head machinery, the effective length of the boom increases by 2 feet.
  12. Power sections of boom must be extended in accordance with the boom mode "A" or "B." In boom mode "B" all power sections must be extended or retracted equally.
  13. The least stable rates working area on outriggers is over the side.
  14. Rated lifting capacities are based on correct reeving. Deduction must be made for excessive reeving. Any reeving over minimum required (See Wire Rope Strength) is considered excessive and must be accounted for when making lifts. Use working range diagram to estimate the extra feet of rope then deduct 1 lb. for each extra foot of wire rope before attempting to lift the load.
  15. The loaded boom angle combined with the boom length give only an approximation of the operating radius. The boom angle, before loading, should be greater to account for deflection. For main boom capacities, the loaded boom angle is for reference only. For fly capacities, the load radius is for reference only.
  16. For fly capacities with main boom length less than 110 ft. and greater than 85 ft., the rated loads are determined by the boom angle using the 110 ft. boom and fly chart. For angles not shown, use the next lower boom angle to determine the allowable capacity.
  17. For fly capacities with main boom length less than 85 ft., the rated loads are determined by the boom angle only using the 85 ft. boom and fly chart. For angles not shown, use the next lower boom angle to determine the allowable capacity.
  18. The 35.5 ft. boom length capacities are based on boom fully retracted. If the boom is not fully retracted, do not exceed capacities shown for the 45 ft. boom length.
  19. Crane capacities on tires depend on tire capacity, condition of tires, and tire air pressure. On tire picks require lifting from main boom head only on a smooth and level surface. Pick and carry operations are restricted to a maximum speed of

2.5 MPH. The boom must be centered over the front of the crane with two position travel swing lock engaged and the load must be restrained from swinging. Lifts with fly erected on tires are prohibited. For correct tire pressure, see "Tire Inflation." Also see Carrier and Tire Inflation Label.

## DEFINITIONS

1. **Load Radius:** Horizontal distance from a projection of the axis of rotation to the supporting surface before loading to the center of the vertical hoist line or tackle with load applied.
2. **Loaded Boom Angle:** The angle between the boom base section and horizontal after lifting the load at the rated radius.
3. **Working Area:** Area measured in a circular arc about the center line of rotation as shown on the working area diagram.
4. **Freely Suspended Load:** Load hanging free with no direct external force applied except by the hoist line.
5. **Side Load:** Horizontal side force applied to the lifted load either on the ground or in the air.
6. **No Load Stability Limit:** The stability limit radius is the radius beyond which it is not permitted to position the boom plus the load handling equipment. Crane may overturn without any load on the hook.

### Boom Mode “A”

Only inner mid section telescopes

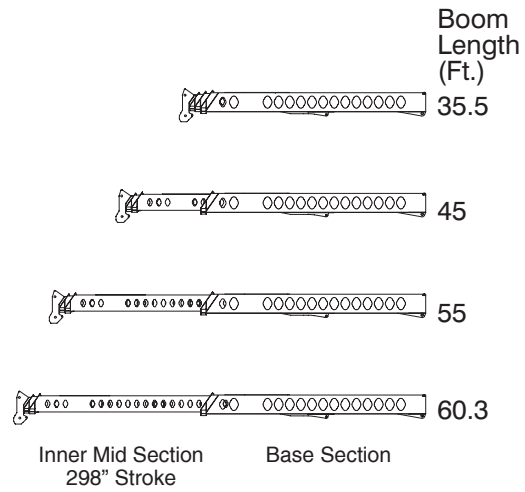

### Boom Mode “B”

Inner mid, outer mid, and tip sections telescope simultaneously

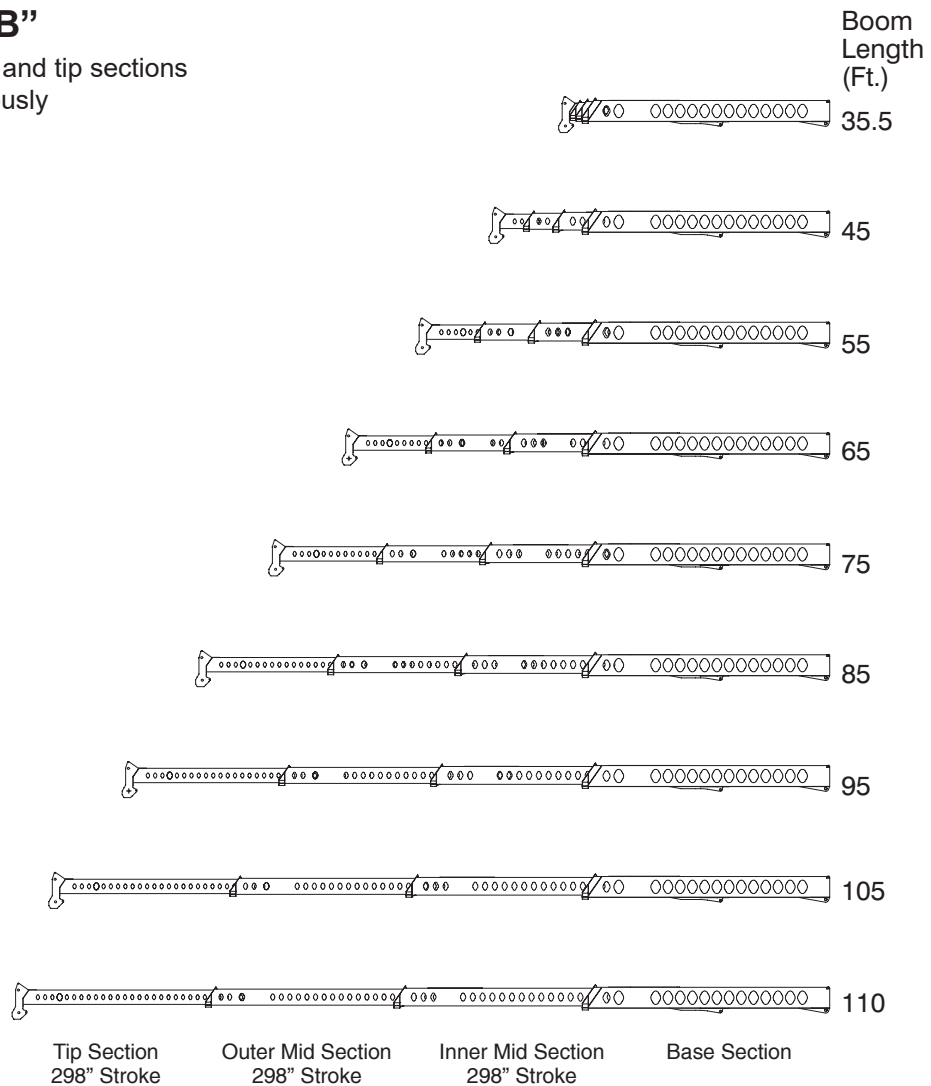

## WINCH PERFORMANCE

Winch Line Pulls			Drum Rope Capacity (ft)	
Two Speed Winch				
Wire Rope Layer	Low Speed	High Speed	Layer	Total
	Available lb	Available lb		
1	16,266*	7,726	102	102
2	14,998*	7,124	111	213
3	13,914*	6,609	120	333
4	12,976*	6,164	128	461
5	12,156	5,774	137	598
6	11,434	5,431	145	743

\* Reduce to 12,920 lb if using Type RB Rope.

## WIRE ROPE STRENGTH

Maximum Lifting Capacities Based On Wire Rope Strength		
Parts of Line	3/4"	Notes
	Type RB	
1*	12,920	Capacities shown are in pounds and working loads must not exceed the ratings on the capacity charts in the Crane Rating Manual. Study Operator's Manual for wire rope inspection procedures. *Use of swivel end with 1 part of line is not recommended.
2	25,840	
3	38,760	
4	51,680	
5	64,600	
6	77,520	
7	90,440	
8	103,360	
9	116,280	
10	129,200	
LBCE	DESCRIPTION	
TYPE RB	18 X 19 Rotation Resistant – Extra Improved Plow Steel – Preformed Right Lay – Regular Lay, Swaged	

## CAPACITY DEDUCTIONS FOR AUXILIARY LOAD HANDLING EQUIPMENT

Load Handling Equipment	Weight (lb)
Auxiliary Head Attached	150
60 Ton Hook Block (See Hook Block For Actual Weight)	1,100
40 Ton Hook Block (See Hook Block For Actual Weight)	720
8.5 Ton Hook Ball (See Hook Ball For Actual Weight)	360
<b>Lifting From Main Boom With:</b>	
22 Ft. Fly Tip Stowed On Boom Base	300
34 Ft. Offset Fly Stowed On Boom Base	900
34 Ft. Offset Fly Erected But Not Used	4,400
56 Ft. Offset Fly Stowed On Boom Base	1,200
56 Ft. Offset Fly Erected But Not Used	7,800
<b>Lifting From 34 Ft. Offset Fly With:</b>	
22 Ft. Fly Tip Stowed On Boom Base	300
22 Ft. Tip Erected But Not Used	<b>PROHIBITED</b>
22 Ft. Tip Stowed On 34 Ft. Offset Fly	<b>PROHIBITED</b>
<b>Note: Capacity deductions are for manufacturer-supplied equipment only.</b>	

## TIRE INFLATION

Tire Size	Operation	Tire Pressure (psi)
29.5 X 25 – 28 PR	2.5 mph	65
	Stationary	75

## PONTOON LOADINGS

Maximum Pontoon Load:	Maximum Pontoon Ground Bearing Pressure:
94,000 lb	208 psi

## OUTRIGGER SPREAD

Position	Distance
Fully Retracted	108.75" – (9' – .75")
Intermediate Extended	186" – (15' – 6")
Fully Extended	264" – (22' – 0")

# WORKING AREAS

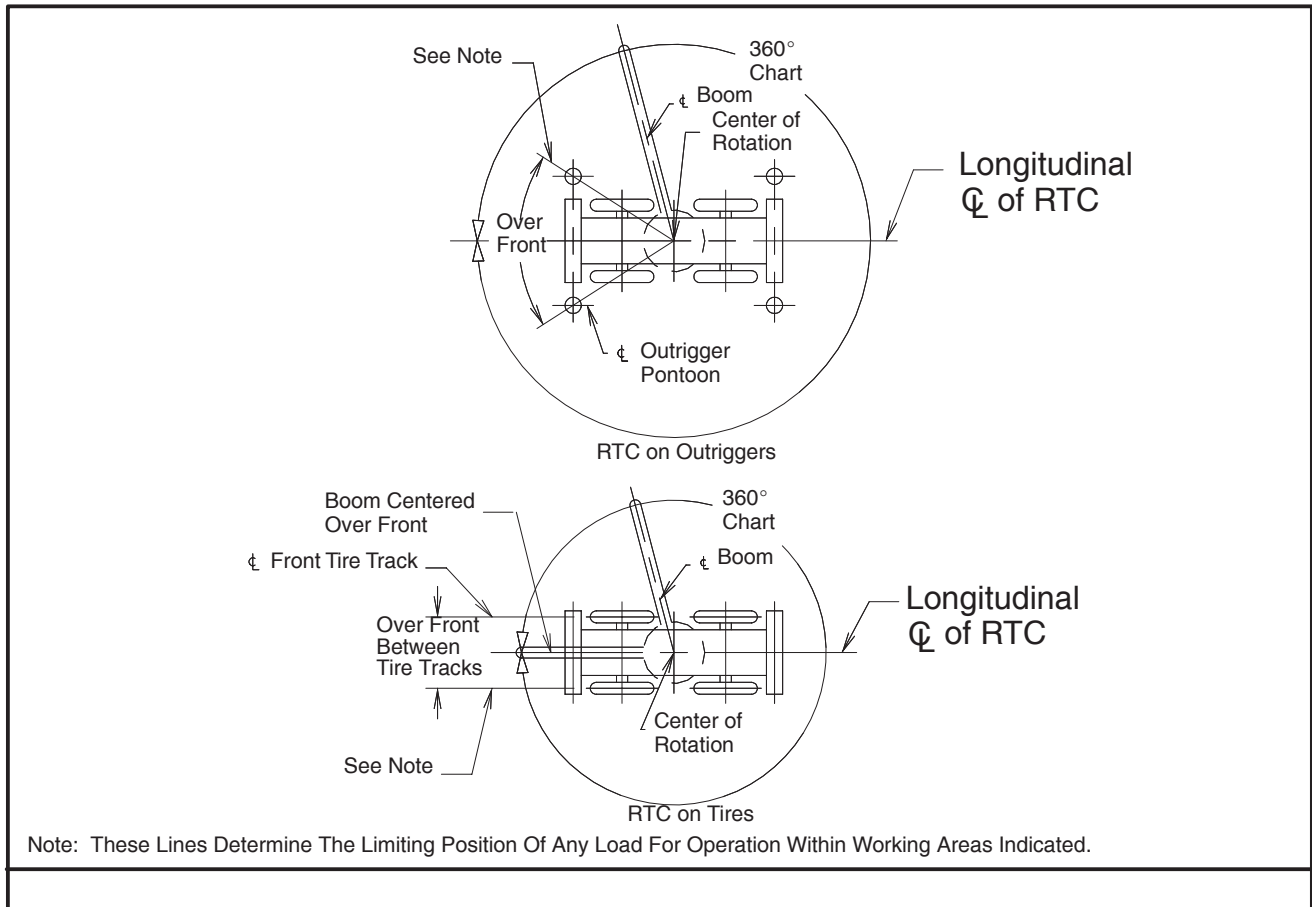

# HYDRAULIC CIRCUIT PRESSURE SETTINGS

Function	Pressure
Front And Rear Winch	2,750 psi
Outrigger	3,000 psi
Boom Hoist	2,900 psi
Telescope	3,000 psi
Swing	1,500 psi
Steering	2,500 psi



# WORKING RANGE DIAGRAM

Working Range Diagram  
On Fully Extended Outriggers

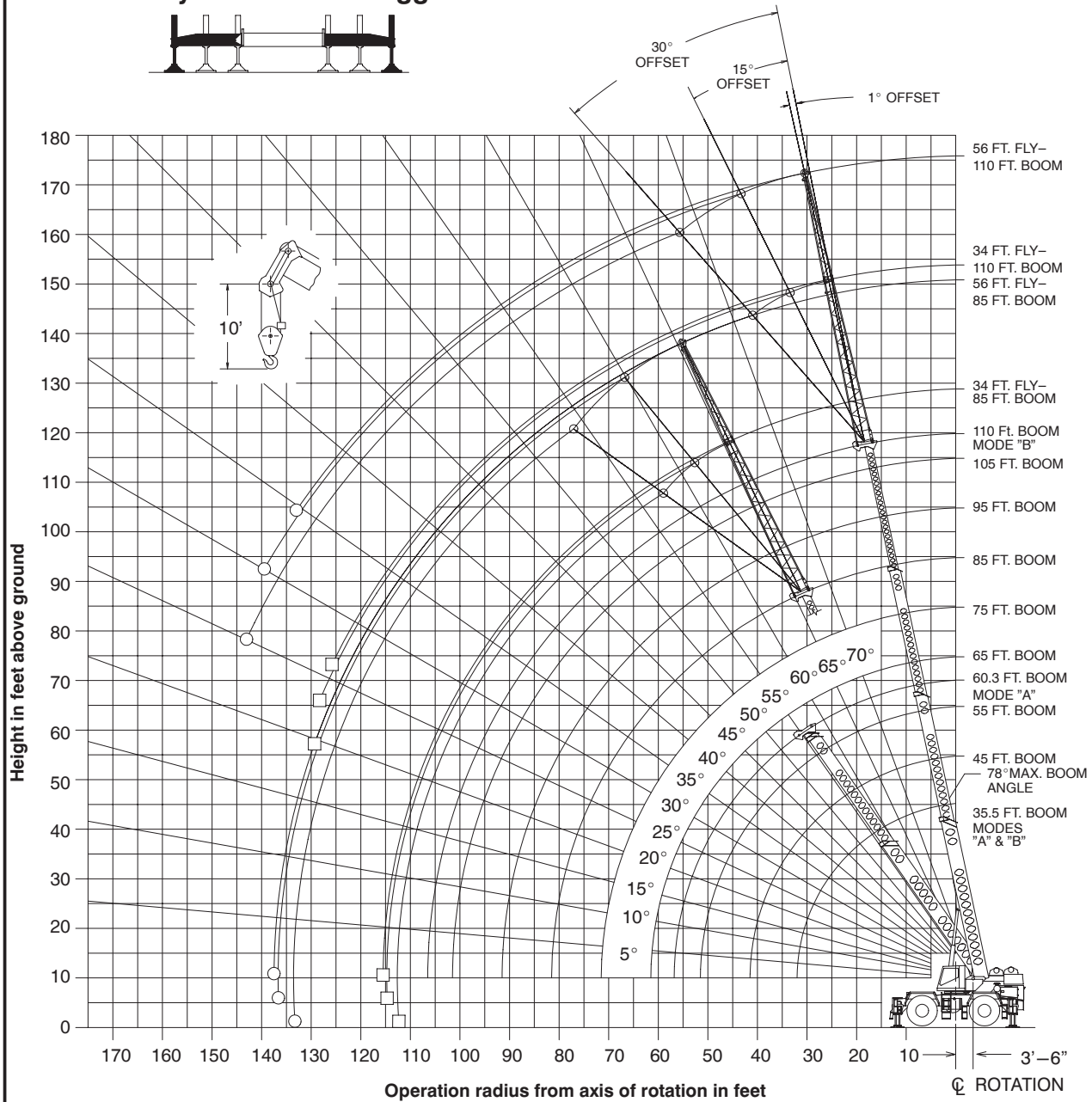

- Denotes Main Boom + 56' Fly—Boom Mode "B"
- Denotes Main Boom + 34' Fly—Boom Mode "B"

**Note:** Boom and fly geometry shown are for unloaded condition and crane standing level on firm supporting surface. Boom deflection, subsequent radius and boom angle change must be accounted for when applying load to hook.



## WARNING

**Do Not Lower The Boom Below The Minimum Boom Angle For No Load As Shown In The Above Chart For The Boom Lengths Shown. Loss Of Stability Will Occur Causing A Tipping Condition.**

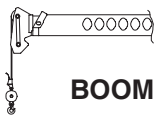

**BOOM MODE "A"**

**Maximum Allowable Lifting Capacities  
Rated Lifting Capacities In Pounds  
On Fully Extended Outriggers  
See Set Up Note 2.**

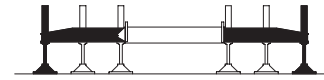

35.5 Ft. To 45 Ft. Main Boom

Load Radius In Feet	35.5 Ft.			45 Ft.			Load Radius In Feet
	Loaded Boom Angle (Deg.)	360°	Over Front	Loaded Boom Angle (Deg.)	360°	Over Front	
10	68.5	100,000	100,000	73.5	87,200	87,200	10
12	65.0	100,000	100,000	71.0	87,200	87,200	12
15	59.5	90,800	90,800	66.5	82,500	82,500	15
20	49.5	71,400	71,400	59.5	67,400	67,400	20
25	37.5	55,800	56,300	51.5	55,100	55,600	25
30	20.0	38,700	40,500	43.0	38,300	40,500	30
35				32.0	28,300	32,700	35
40				15.5	21,800	25,200	40
Min. Boom Angle/Cap.	0°	20,900	20,900	0°	14,000	14,000	Min. Boom Angle/Cap.

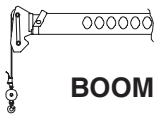

**BOOM MODE "A"**

**Maximum Allowable Lifting Capacities  
Rated Lifting Capacities In Pounds  
On Fully Extended Outriggers  
See Set Up Note 2.**

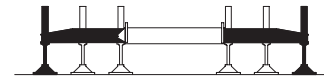

55 Ft. To 60.3 Ft. Main Boom

Load Radius In Feet	55 Ft.			60.3 Ft.			Load Radius In Feet
	Loaded Boom Angle (Deg.)	360°	Over Front	Loaded Boom Angle (Deg.)	360°	Over Front	
10	77.0	79,700	79,700				10
12	75.0	72,400	72,400	76.5	61,400	61,400	12
15	71.5	63,500	63,500	73.5	57,600	57,600	15
20	66.0	52,300	52,300	68.5	47,100	47,100	20
25	60.0	44,200	44,200	63.0	39,500	39,500	25
30	53.5	37,800	38,000	57.5	33,900	33,900	30
35	47.0	27,900	32,300	51.5	27,700	29,700	35
40	39.0	21,500	24,900	45.0	21,400	24,800	40
45	29.0	17,000	19,700	37.5	16,800	19,600	45
50	14.5	13,500	15,800	28.5	13,400	15,800	50
55				15.0	10,800	12,800	55
Min. Boom Angle/Cap.	0°	9,000	9,000	0°	7,100	7,100	Min. Boom Angle/Cap.

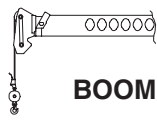

**BOOM MODE "B"**

**Maximum Allowable Lifting Capacities  
Rated Lifting Capacities In Pounds  
On Fully Extended Outriggers  
See Set Up Note 2.**

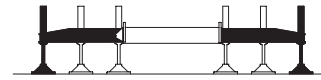

**35.5 Ft. To 55 Ft. Main Boom**

Load Radius In Feet	35.5 Ft.			45 Ft.			55 Ft.			Load Radius In Feet
	Loaded Boom Angle (Deg.)	360°	Over Front	Loaded Boom Angle (Deg.)	360°	Over Front	Loaded Boom Angle (Deg.)	360°	Over Front	
10	68.5	100,000	100,000	73.0	42,000	42,000	76.5	42,000	42,000	10
12	65.0	100,000	100,000	70.5	42,000	42,000	74.5	42,000	42,000	12
15	59.5	90,800	90,800	66.5	42,000	42,000	71.5	42,000	42,000	15
20	49.5	71,400	71,400	59.5	42,000	42,000	66.0	42,000	42,000	20
25	37.5	55,800	56,300	51.5	42,000	42,000	60.0	42,000	42,000	25
30	20.0	38,700	40,500	43.0	39,800	40,500	53.5	40,400	40,500	30
35				32.0	29,800	34,200	46.5	30,400	34,800	35
40				15.5	23,100	26,500	38.5	23,800	27,200	40
45							29.0	19,100	22,000	45
50							14.0	15,600	18,000	50
Min. Boom Angle/ Cap.	0°	20,900	20,900	0°	15,100	15,100	0°	10,900	10,900	Min. Boom Angle/ Cap.

**65 Ft. To 85 Ft. Main Boom**

Load Radius In Feet	65 Ft.			75 Ft.			85 Ft.			Load Radius In Feet
	Loaded Boom Angle (Deg.)	360°	Over Front	Loaded Boom Angle (Deg.)	360°	Over Front	Loaded Boom Angle (Deg.)	360°	Over Front	
12	77.0	42,000	42,000							12
15	74.5	42,000	42,000	77.0	42,000	42,000				15
20	70.0	42,000	42,000	73.0	42,000	42,000	75.5	36,000	36,000	20
25	65.5	42,000	42,000	69.0	41,700	41,700	72.0	31,500	31,500	25
30	60.5	40,700	40,500	65.0	37,100	37,100	68.5	28,200	28,200	30
35	55.0	30,700	35,100	60.5	30,900	32,500	64.5	25,400	25,400	35
40	49.0	24,200	27,600	56.0	24,400	27,800	61.0	23,000	23,000	40
45	43.0	19,500	22,300	51.0	19,700	22,600	57.0	19,900	21,100	45
50	35.5	16,000	18,400	46.0	16,300	18,700	52.5	16,400	18,800	50
55	27.0	13,300	15,400	40.0	13,600	15,600	48.0	13,700	15,800	55
60	13.5	11,100	12,900	33.5	11,500	13,200	43.0	11,700	13,400	60
65				25.0	9,700	11,300	38.0	9,900	11,500	65
70				12.5	8,200	9,700	31.5	8,400	9,900	70
75							24.0	7,200	8,500	75
80							12.0	6,100	7,300	80
Min. Boom Angle/ Cap.	0°	8,000	8,000	0°	5,900	5,900	0°	4,300	4,300	Min. Boom Angle/ Cap.

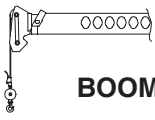

**BOOM MODE "B"**

**Maximum Allowable Lifting Capacities  
Rated Lifting Capacities In Pounds  
On Fully Extended Outriggers  
See Set Up Note 2.**

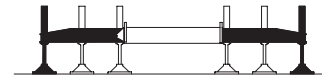

95 Ft. To 110 Ft. Main Boom

Load Radius In Feet	95 Ft.			105 Ft.			110 Ft.			Load Radius In Feet
	Loaded Boom Angle (Deg.)	360°	Over Front	Loaded Boom Angle (Deg.)	360°	Over Front	Loaded Boom Angle (Deg.)	360°	Over Front	
20	77.5	31,800	31,800							20
25	74.5	28,300	28,300	76.0	25,700	25,700	77.0	22,500	22,500	25
30	71.0	25,300	25,300	73.5	23,100	23,100	74.5	22,200	22,200	30
35	68.0	22,900	22,900	70.5	20,900	20,900	72.0	20,100	20,100	35
40	64.5	20,800	20,800	67.5	19,000	19,000	69.0	18,300	18,300	40
45	61.5	19,000	19,000	65.0	17,400	17,400	66.0	16,700	16,700	45
50	58.0	16,500	17,500	61.5	15,900	15,900	63.5	15,200	15,200	50
55	54.0	13,800	15,900	58.5	13,900	14,700	60.5	13,900	13,900	55
60	50.0	11,800	13,500	55.0	11,900	13,600	57.0	11,900	12,500	60
65	45.5	10,000	11,700	51.5	10,100	11,800	54.0	10,200	11,200	65
70	41.0	8,600	10,000	48.0	8,700	10,100	50.5	8,700	10,100	70
75	36.0	7,300	8,700	43.5	7,400	8,800	47.0	7,500	8,800	75
80	30.0	6,300	7,500	39.5	6,400	7,600	43.0	6,400	7,700	80
85	23.0	5,400	6,500	34.5	5,500	6,600	38.5	5,500	6,700	85
90	12.0	4,500	5,600	29.0	4,700	5,700	34.0	4,700	5,800	90
95				22.0	4,000	4,900	28.5	4,000	5,000	95
100				11.5	3,300	4,200	22.0	3,400	4,300	100
105							11.0	2,800	3,700	105
Min. Boom Angle/ Cap.	0°	3,100	3,100	0°	2,100	2,100	0°	1,700	1,700	Min. Boom Angle/ Cap.

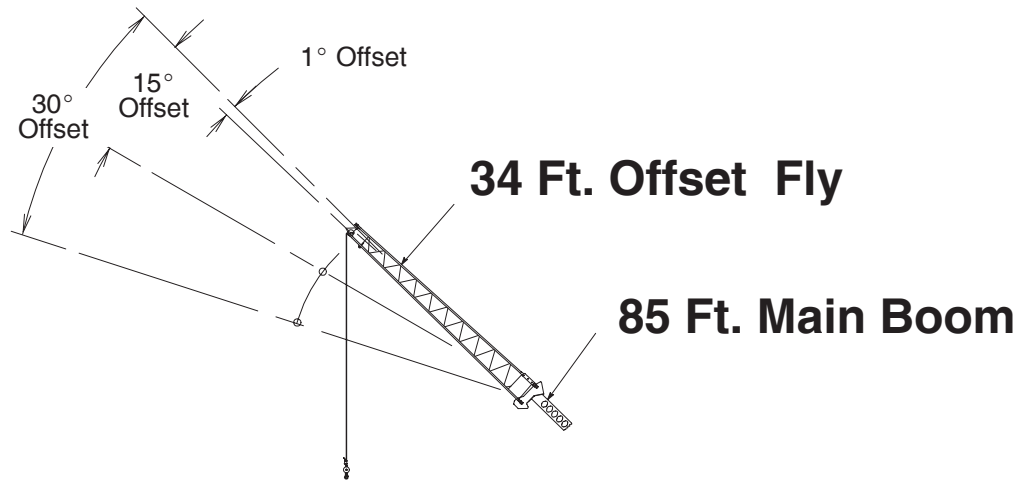

<b>BOOM MODE "B"</b>							
<b>Maximum Allowable Lifting Capacities</b> <b>Rated Lifting Capacities In Pounds</b> <b>On Fully Extended Outriggers</b> <b>See Set Up Note 2.</b>							
85 Ft. Main Boom + 34 Ft. Offset Fly							
Load Radius In Feet	1° Offset		15° Offset		30° Offset		Load Radius In Feet
	Loaded Boom Angle (Deg.)	360°	Loaded Boom Angle (Deg.)	360°	Loaded Boom Angle (Deg.)	360°	
25	77.5	18,600					25
30	75.0	17,000					30
35	73.0	15,600	76.5	12,000			35
40	70.5	14,500	74.0	11,400	77.5	9,400	40
45	68.0	13,600	71.5	10,800	75.0	9,100	45
50	65.5	12,700	69.0	10,400	72.5	8,800	50
55	62.5	11,900	66.5	9,900	69.5	8,400	55
60	60.0	11,100	63.5	9,500	67.0	8,100	60
65	57.0	10,300	60.5	9,100	64.0	7,800	65
70	54.0	9,600	58.0	8,800	61.0	7,500	70
75	51.0	8,600	54.5	8,400	58.0	7,300	75
80	47.5	7,500	51.5	8,000	54.5	7,100	80
85	44.0	6,600	48.0	7,000	51.0	6,900	85
90	40.0	5,800	44.0	6,100	47.0	6,400	90
95	36.0	5,100	39.5	5,400	42.5	5,600	95
100	31.5	4,400	35.0	4,700	37.5	4,900	100
105	26.0	3,900	29.5	4,100	31.5	4,200	105
110	19.5	3,400	22.5	3,500	23.0	3,500	110
Min. Boom Angle/Cap.	0°	1,800	0°	1,800	0°	1,900	Min. Boom Angle/Cap.

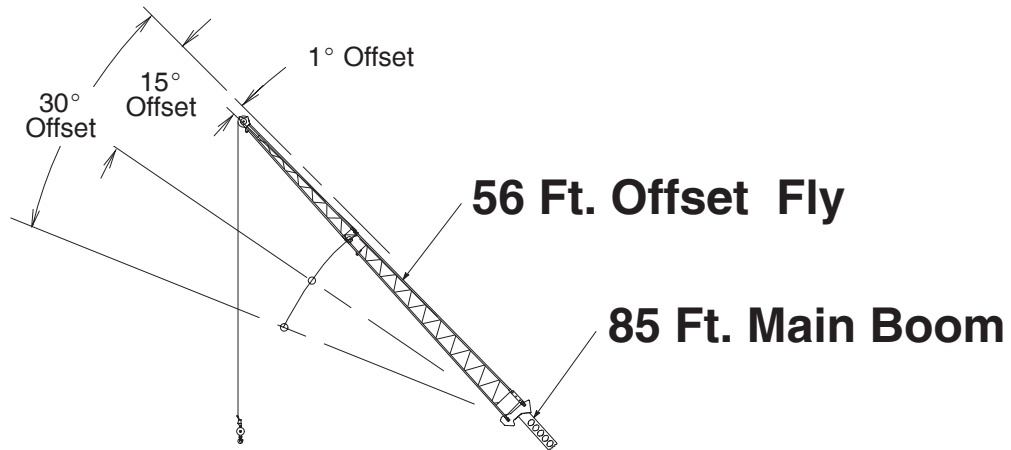

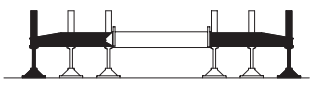
<b>BOOM MODE "B"</b> <span style="float: right;">  </span>							
<b>Maximum Allowable Lifting Capacities</b> <b>Rated Lifting Capacities In Pounds</b> <b>On Fully Extended Outriggers</b> <b>See Set Up Note 2.</b>							
85 Ft. Main Boom + 56 Ft. Offset Fly							
Load Radius In Feet	1° Offset		15° Offset		30° Offset		Load Radius In Feet
	Loaded Boom Angle (Deg.)	360°	Loaded Boom Angle (Deg.)	360°	Loaded Boom Angle (Deg.)	360°	
35	76.5	11,100					35
40	74.5	10,500					40
45	72.5	9,600	77.5	7,100			45
50	70.0	8,800	75.5	6,700			50
55	68.0	8,100	73.0	6,300			55
60	66.0	7,600	71.0	5,900	76.0	4,800	60
65	63.5	7,000	69.0	5,600	74.0	4,600	65
70	61.5	6,600	66.5	5,300	71.5	4,500	70
75	59.0	6,200	64.0	5,100	69.0	4,300	75
80	56.5	5,800	61.5	4,800	66.5	4,100	80
85	54.0	5,500	59.0	4,600	64.0	4,000	85
90	51.5	5,200	56.5	4,400	61.5	3,900	90
95	49.0	4,900	54.0	4,300	58.5	3,800	95
100	46.0	4,700	51.0	4,100	55.5	3,700	100
105	43.0	4,400	48.0	3,900	52.0	3,600	105
110	39.5	4,000	44.5	3,800	49.0	3,500	110
115	36.0	3,500	41.0	3,700	45.0	3,400	115
120	32.0	3,100	37.0	3,300	40.5	3,400	120
125	27.5	2,700	32.5	2,900	35.0	3,000	125
130	22.0	2,300	26.5	2,500	28.0	2,500	130
135	14.5	2,000	18.0	2,100			135
Min. Boom Angle/Cap.	0°	900	0°	900	0°	1,000	Min. Boom Angle/Cap.

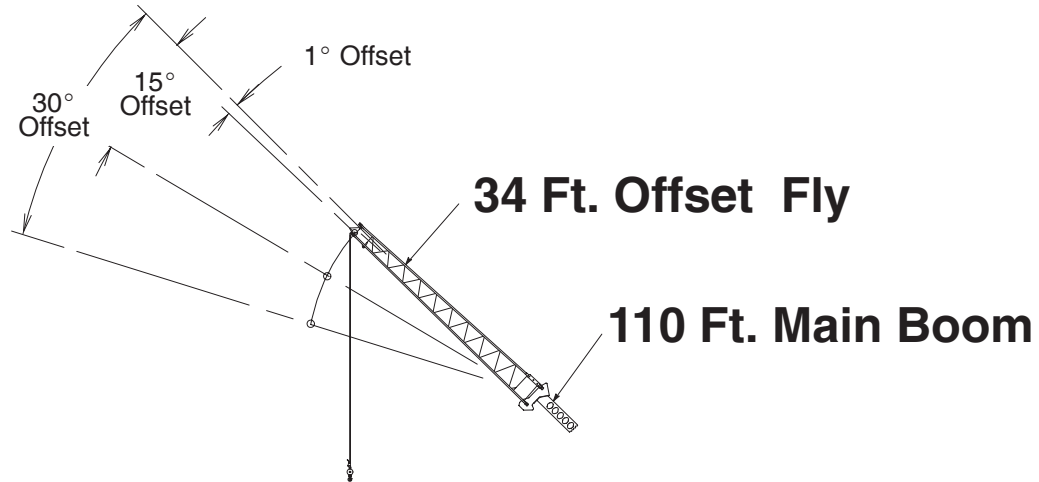

**BOOM MODE "B"**

**Maximum Allowable Lifting Capacities  
Rated Lifting Capacities In Pounds  
On Fully Extended Outriggers  
See Set Up Note 2.**

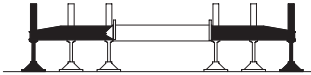

110 Ft. Main Boom + 34 Ft. Offset Fly							
Load Radius In Feet	1° Offset		15° Offset		30° Offset		Load Radius In Feet
	Loaded Boom Angle (Deg.)	360°	Loaded Boom Angle (Deg.)	360°	Loaded Boom Angle (Deg.)	360°	
35	76.5	10,500					35
40	74.5	10,500					40
45	72.5	10,500	76.0	9,800			45
50	70.5	9,800	74.0	9,000	77.0	8,300	50
55	68.5	8,900	71.5	8,200	75.0	7,700	55
60	66.5	8,200	69.5	7,600	72.5	7,100	60
65	64.0	7,500	67.5	7,000	70.5	6,600	65
70	62.0	6,900	65.0	6,500	68.0	6,200	70
75	59.5	6,400	63.0	6,100	65.5	5,800	75
80	57.5	6,000	60.5	5,700	63.0	5,500	80
85	55.0	5,600	58.0	5,300	60.5	5,100	85
90	52.5	5,100	55.5	5,000	58.0	4,800	90
95	49.5	4,700	53.0	4,700	55.5	4,600	95
100	47.0	4,200	50.0	4,300	52.5	4,300	100
105	43.5	3,600	47.0	3,900	49.5	4,000	105
110	40.5	3,100	43.5	3,400	46.0	3,600	110
115	37.0	2,600	40.5	2,900	42.5	3,100	115
120	33.5	2,200	36.5	2,400	38.5	2,600	120
125	29.5	1,800	32.5	2,000	34.0	2,100	125
130			27.5	1,600	28.5	1,700	130

**⚠ WARNING**

**Do Not Lower 34 Ft. Offset Fly In Working Position Below 26 Degrees Unless Main Boom Length Is 98 Ft. Or Less, Since Loss Of Stability Will Occur Causing A Tipping Condition.**



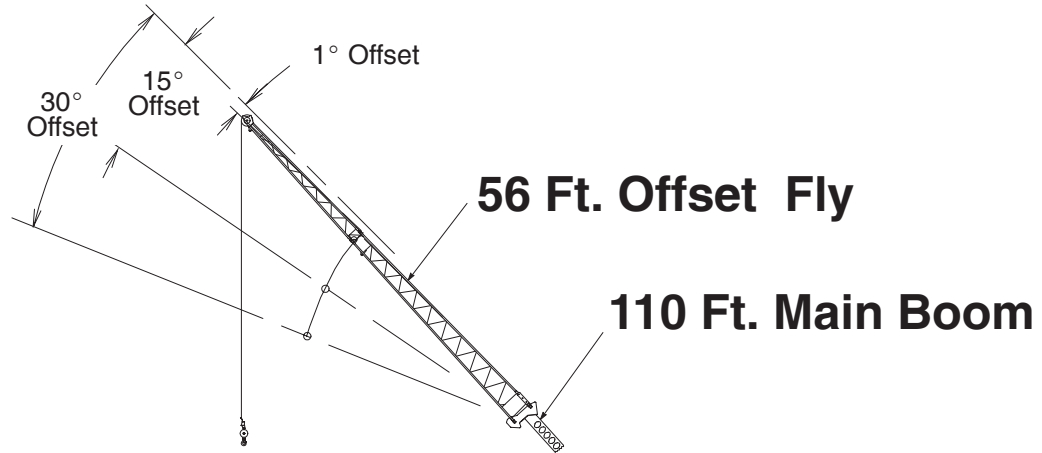

**BOOM MODE "B"**

**Maximum Allowable Lifting Capacities  
Rated Lifting Capacities In Pounds  
On Fully Extended Outriggers  
See Set Up Note 2.**



110 Ft. Main Boom + 56 Ft. Offset Fly							
Load Radius In Feet	1° Offset		15° Offset		30° Offset		Load Radius In Feet
	Loaded Boom Angle (Deg.)	360°	Loaded Boom Angle (Deg.)	360°	Loaded Boom Angle (Deg.)	360°	
40	77.0	7,000					40
45	75.5	7,000					45
50	74.0	7,000					50
55	72.5	7,000	77.5	6,400			55
60	71.0	6,400	75.5	5,900			60
65	69.0	5,900	73.5	5,400	78.0*	5,000	65
70	67.0	5,400	71.5	5,000	76.0	4,600	70
75	65.0	5,000	70.0	4,600	74.0	4,300	75
80	63.0	4,600	68.0	4,300	72.0	4,000	80
85	61.5	4,300	66.0	4,000	70.0	3,800	85
90	59.5	4,000	64.0	3,700	68.0	3,500	90
95	57.0	3,700	61.5	3,500	66.0	3,300	95
100	55.0	3,500	59.5	3,300	63.5	3,100	100
105	53.0	3,300	57.5	3,100	61.5	2,900	105
110	50.5	3,100	55.0	2,900	59.0	2,800	110
115	48.5	2,900	53.0	2,700	56.5	2,600	115
120	46.0	2,600	50.5	2,600	54.0	2,500	120
125	43.0	2,300	47.5	2,400	51.0	2,300	125
130	40.5	1,900	45.0	2,200	48.0	2,100	130
135	37.5	1,600	42.0	1,900	45.0	1,900	135
140			38.5	1,500	41.5	1,700	140
145					37.0	1,400	145

**⚠ WARNING**

**Do Not Lower 56 Ft. Offset Fly In Working Position Below 34.5 Degrees Unless Main Boom Length Is 89 Ft. Or Less, Since Loss Of Stability Will Occur Causing A Tipping Condition.**



**CCO**

2750 Prosperity Avenue, Suite 505  
Fairfax, VA 22031-4312

Phone: 703-560-2391  
info@nccco.org  
www.nccco.org